

MVR Bars Deep Face Grooving - with 2 Coolant Bores

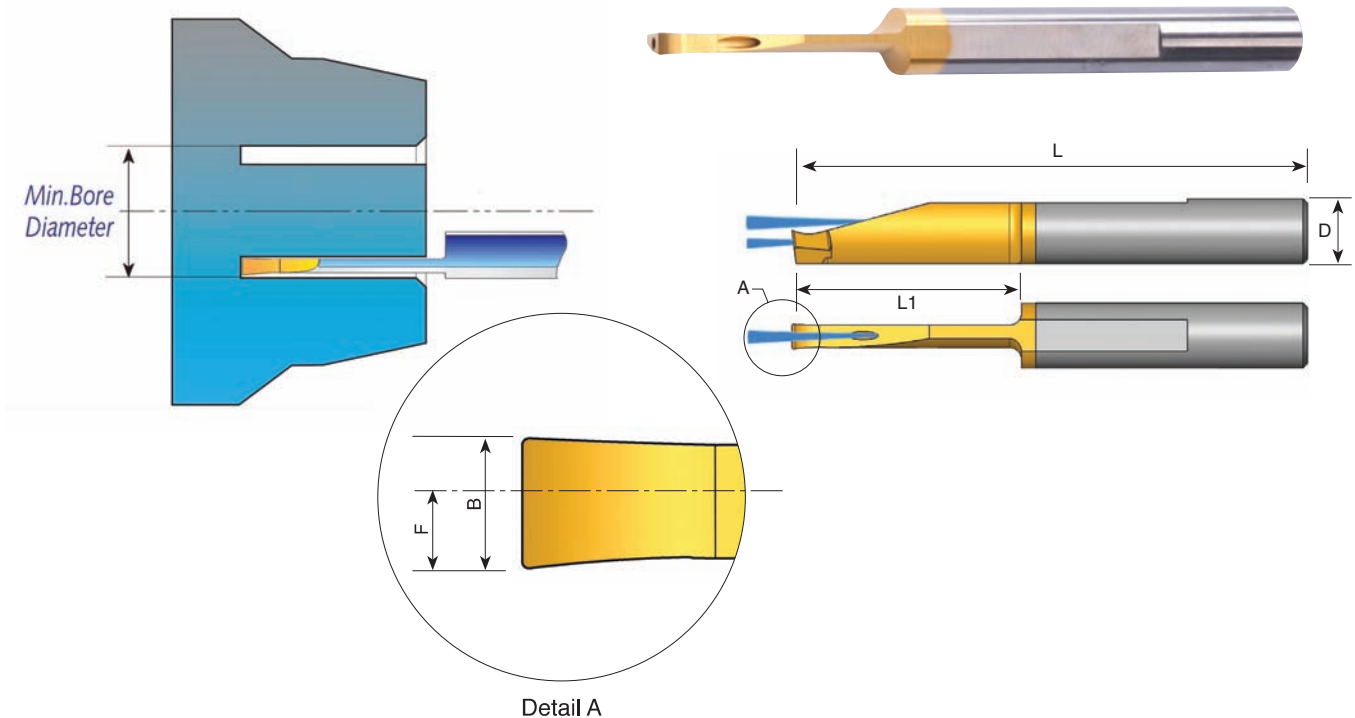

Detail A

| D | Ordering Code | L | L1 | B | F | Min. Bore Dia. | Holder* |
|-----|-----------------------|----|----|-----|-----|----------------|-------------|
| 6.0 | MVR 6 B2.0 L15 | 51 | 15 | 2.0 | 1.7 | 12.0 | SIM 0020 H6 |
| 6.0 | MVR 6 B2.0 L22 | 51 | 22 | 2.0 | 1.7 | 12.0 | SIM 0020 H6 |
| 6.0 | MVR 6 B2.5 L22 | 51 | 22 | 2.5 | 2.2 | 12.0 | SIM 0020 H6 |
| 8.0 | MVR 8 B3.0 L27 | 51 | 27 | 3.0 | 2.5 | 15.0 | SIM 0020 H8 |

Order example: MVR 6 B2.0 L22 BXC

* For additional holders see page 156